

**TFB-5160 BK**  
Cod. **02034408** EAN **8422248108096**

- Mechanical control panel**
- 2 extraction levels
- Extraction power (according to UNE/EN 61591): **300m<sup>3</sup>/h** - 160m<sup>3</sup>/h
- Sound power (Reg.(EU) n°65/2014): 48dB(A)**, maximum: 61dB(A)
- Tangential motor. Extra silent. Maximum energy consumption **65W**
- High efficiency Strip LED lighting**
- Easy-to-install system
- Dishwasher-washable filters
- Finished in black
- Max. pressure 170Pa
- 150mm outlet diameter
- Energy Class: C

► **Accessories (not included)**

Active charcoal filter .....Cod. 02859495 / EAN 8422248100281 .....

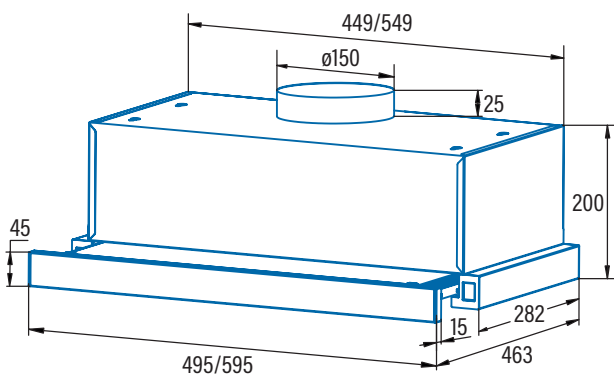

<b>Code</b>	<b>02034408</b>
<b>EAN</b>	<b>8422248108096</b>
<b>Model</b>	<b>TFB-5160 BK</b>
<b>Type</b>	Telescopic
<b>Product fiche according to directives EU65/2014 - EN61591, EN60704-2-13, EN50564</b>	
AEC (Annual Energy consumption) (kWh/annum)	36,5
EEL class (Energy Efficiency Class)	C
FDE (Fluid Dynamic Efficiency)	8,86
FDE class (Fluid Dynamic Efficiency Class)	E
LE (Lighting Efficiency) (lux/W)	43,9
LE class (Lighting Efficiency Class)	A
GFE (Grease Filtering Efficiency)	60,6
GFE Class (Grease Filtering Efficiency class)	E
Air flow at minimum speed (m3/h)	158,4
Air flow at maximum speed (m3/h)	297,2
Air flow at intensive speed (TURBO) (m3/h)	-
Sound Power Level at minimum speed (dB)	47,8
Sound Power Level at maximum speed (dB)	61,1
Sound Power Level at intensive speed (TURBO) (dB)	-
Po (Power Consumption in off mode) (W)	0
Ps (Power Consumption in standby) (W)	-
<b>Integration directive EU 66/2014</b>	
f (Time Increase Factor)	1,68
EEL (Energy Efficiency Index)	76,34
QBEP (Flow Rate at Best Efficiency Point) (m3/h)	158,4
PBEP (Static Pressure Difference at Best Efficiency Point) (Pa)	115,03
WBEP (Electric Power Input at Best Efficiency Point) (W)	57,11
WL (Nominal Power Consumption of Lighting system) (W)	2
EMIDDLE (Average Illumination of Lighting system on Cooking surface) (lux)	87,8
<b>External Dimensions</b>	
Width (mm)	595
Depth (mm)	297
Total max height(mm)	200
Total min height(mm)	225
Outlet Diameter (mm)	150
<b>Characteristics</b>	
Motor	TT300
Extraction Levels	2
Motor Maximum Power Consumption	65
Maximum Pressure	170
Intensive Speed (TURBO) Pressure	-
Control Type	Rocker Switch
Automatic shut-down timer	-
Electronic Filter Saturation Indicator	-
Filter Type	Metallic
Anti-grease Filter Number	2
Inner Shield	√
<b>Lighting</b>	
Light Type	CSLED
Adjustable Intensity Lighting	-
N° of Lamps	1
<b>Installation</b>	
Minimum height distance to a electric worktop hob (mm)	550
Minimum height distance to a gas worktop hob (mm)	650
Installation with Outlet tube to the exterior / Recirculating	BOTH
Easy Installation System	√
<b>Electric Connection</b>	
Total Rush Power (W)	67
Rated Voltage (V)	220-240
Network Frequency (Hz)	50 / 60
Electrical Insulation Class	CLASS I
Plug	VDE
<b>Accessories</b>	
Upper Decorative tube Extension	-
White Decorative Tube	-
Black Decorative Tube	-
Island Tube Enhancer	-
Check Valve	-
MAX PRO Metal Filter	-
Metal Filter	02800981
DUAL Filter (metal + active charcoal)	-
Active Charcoal Filter	02859495
Noiseless Flexible Duct	-