



CMD 5008 X

FAN FORCED Oven



CMD 5008 X

Cod. **07003307** EAN **8422248067881**

- Multifunction oven - 8 functions
- Push/Pull controls
- Digital cooking programmer
- Temperature range 50°C-250°C
- 4 levels for placing easy-to-move trays
- 1 Telescopic guide full extension adaptable to any level
- Panoramic easy-to-clean full glass door with removable inner glass
- Triple glazed cool door with tangential ventilation
- Accessories: Deep tray and grid
- AquaSmart Cleaning system
- Stainless steel and black glass finishing
- Built into a 45cm unit
- 60cm wide
- Net capacity 40 litres
- 220/240V 50/60Hz
- Energy Class A

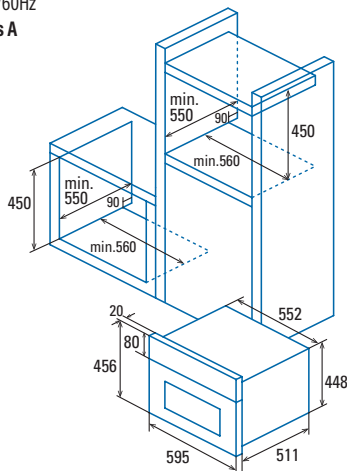

Code	07003307
EAN	8422248067881
Model	CMD5008X
Type	Multifunction Turbo
Product fiche according to EU 65/2014 y EU 66/2014	
Energy efficiency index (IEE)	97,2
Energy efficiency Class	A
Energy consumption in conventional mode [kWh/cycle]	0,7
Energy consumption in fan-forced mode [kWh/cycle]	0,71
Number of cavities	1
Heat source	Electricity
Mass of the appliance [Kg]	30,4
Cavity volume (L)	40
Dimensions	
Width [mm]	456
Height [mm]	595
Depth [mm]	502
Cavity width [mm]	260
Cavity height [mm]	450
Cavity depth [mm]	456
Characteristics	
Finishing	Stainless steel
Soft Door closing	No
Tray levels	4
Convection Fan	Yes
Number of light bulbs	1
Controls	
Control type	Touch with push-pull knobs
Screen Technology	LCD
Cooking programmer start/stop	Yes
Cooking programmer stop	-
Minute minder	-
Working pilot light	Yes
Thermostat pilot light	Yes
Min. temperature [°C]	50
Max. Temperature [°C]	250
Cleaning	
Enamel	Non-stick black
Cavity type	Flat
Inner glass	Fixed
AquaSmart Cleaning	Manual
Number of programmes	8
Fast preheat	No
Inner light	Yes
Safety	
Safety lock	No
Number of door glasses	3
Cooling fan	Yes
Security Thermostat	Yes
Electrical connection	
Grill power [W]	2200
Bottom heating element power [W]	1300
Back heating element power [W]	2300
Total rated Power [W]	2380
Nominal voltage [V] / Mains frequency [Hz]	220-240 / 50/60
Light power [W]	25
Plug	No
Accessories	
Side racks	1
Grill	1
Shallow tray	-
Deep tray	1
Sliding rails	1
Turnspit	-
Pizza Stone (optional)	-
Gas connection hose	-