



MC 20 IX

Installation suitable
for High Furniture

MC 20 IX
Cod. **07510306** EAN **8422248058476**

- 20 litre built-in microwave
- Simultaneous 1,000 W grill
- Five power levels, 800 W output
- Stainless steel interior**
- Revolving dish ø 245 mm
- Timer from 0 to 95 minutes
- Automatic defrosting by time and weight
- Fast start button
- Easy to install**
- Safety lock
- Finished in stainless steel
- 60cm wide
- Inner measurements 175 x 298 x 320 mm
(high x wide x deep)

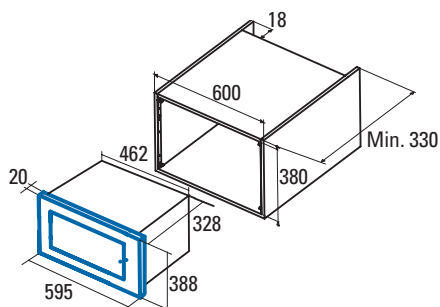

Code	07510306
EAN	8422248058476
Model	MC 20 IX
Type (Built in / free standing)	Built in
DIMENSIONS	
Appliance width [mm]	595
Appliance height [mm]	388
Appliance depth [mm]	347
Cavity width [mm]	295
Cavity height [mm]	218
Cavity depth [mm]	314
Characteristics	
Finishing	Stainless steel
Door opening System	Push button
Cavity capacity [L]	20
Cavity type	Stainless steel
Inside light	Yes
Opening door angle [degrees]	90
Noise level db[A]	63
Controls	
Control type	Mechanic
Display technology	-
Electronic timer	No
Manual timer	Yes
Start/Stop button	No
Timer [min]	35
Power selector	Yes
Function and temperature selector	No
Working indicator	No
Weight selector	No
Programs	
Number of programmes	9
Grill	Yes
Simultaneous grill + microwave	Yes
Convection fan	No
Defrosting, heating and cooking by food type	Yes
Quick start	No
Safety	
Safety thermostat	Yes
Safety automatic disconnection	No
Child safety lock	No
Door temperature	65
N° of glasses in the door	1
Electrical connection	
Grill power [W]	1000
Microwave power [W]	800
Convection power [W]	-
Rated power [W]	1250
Voltage / Frequency [V/Hz]	230 / 50
Power cord length	1000
Plug type	Schuko
Accessories	
Rotatory removable glass	Yes
Diameter of glass dish [mm]	245
Built in frame	Included
Ventilation kit	No