

SURFACE INTEGRATION



IAS 770
Cod. **08000403** EAN **8422248102568**

- Touch Control Panel with timer and cleaning filters indicator
- 5 extraction levels, 4 + 1 TURBO
- Extraction power (according to UNE/EN 61591): 550m³/h - 200m³/h
- Airflow speed: 10 m/s
- Sound power (Reg.(EU) n°65/2014): 45dB(A), maximum: 67dB(A)
- BRUSHLESS motor. Ultra silent. Maximum energy consumption 135W
- Easy-to-install system
- Dishwasher-washable filters
- Max. Pressure: 470 Pa
- 150 mm outlet diameter
- Energy Class: A

► **Accessories (not included)**

- Recirculating kit Socket AS750
Kit de recirculation Socket AS750Cod. 02800939 / EAN 8422248080330
- Filter replacement kit washable active carbon
Kit de remplacement de filtre charbon actif lavableCod. 02800937 / EAN 8422248078900
- 0150mm Vertical Round Tube (750mm).....Cod. 15107015 / EAN 8422248080002.....
- 0150mm Vertical Bend 90° Round to Rectangular.....Cod. 15107016 / EAN 8422248080019.....

4 cooking areas:

- Front Right: 1 area **with Booster function** of 215mm x 195mm of 2 kW (max. 2.8kW)
- Rear Right: 1 area **with Booster function** of 215mm x 195mm of 1.5 kW (max. 2kW)
- Front Left: 1 area **with Booster function** of 215mm x 195mm of 2 kW (max. 2.8kW)
- Rear Left: 1 area **with Booster function** of 215mm x 195mm of 1.5 kW (max. 2kW)

2 modular double areas measuring 215mm x 390mm of 3.5kW

- Touch Control with acoustic warning
- 9 adjustable power levels + Booster
- Timer function for each area
- Countdown alarm
- Automatic pan detection
- Safety lock
- Residual heat indicator
- Automatic safety switch-off
- 77 cm wide**
- Total power (induction + extraction) 7.335kW**



► **Accessories (not included)**

- Barbecue grillCod. 03017400 / EAN 8422248082563

Code	08000403
EAN	8422248102568
Model	IAS 770
Type	Surface
Product fiche	
Cooking zones	4
Right front zone: Diameter (mm)	190x190
Right front zone: Power (kW)	2
Right front zone: Booster (kW)	2,8
Right front zone: Consumption (Wh/kg)	206,8
Right rear zone: Diameter (mm)	190x190
Right rear zone: Power (kW)	1,5
Right rear zone: Booster (kW)	2
Right rear zone: Consumption (Wh/kg)	181,5
Central front zone: Diameter (mm)	-
Central front zone: Power (kW)	-
Central front zone: Booster (kW)	-
Central front zone: Consumption (Wh/kg)	-
Central rear zone: Diameter (mm)	-
Central rear zone: Power (kW)	-
Central rear zone: Booster (kW)	-
Central rear zone: Consumption (Wh/kg)	-
Front left zone: Diameter (mm)	190x190
Front left zone: Power (kW)	2
Front left zone: Booster (kW)	2,8
Front left zone: Consumption (Wh/kg)	194,2
Left rear zone: Diameter (mm)	190x190
Left rear zone: Power (kW)	1,5
Left rear zone: Booster (kW)	2
Left rear zone: Consumption (Wh/kg)	181,5
Energy consumption of the hob (Wh/kg)	194,2
Dimensions	
Product width (mm)	770
Product depth (mm)	520
Product height (mm)	250
Built-in height (mm)	750
Built-in depth (mm)	490
Ventilation slot (mm)	5
Fixing system	Quick-fix System
Finishing	
Colour	Black
Aesthetic	Front bevel
Control	
Control type	Touch
Power selection (+/-)	Centralized
Power levels	9 + Booster
Timer	Yes
Countdown alarm	Yes
Power management	No
Security	
Safety lock	Yes
Residual heat indicator	Yes
Automatic pan detection	Yes
Automatic safety switch-off	Yes
Protection against liquid spillage	Yes
Electrical connection	
Nominal voltage (V)	220-240
Mains frequency (Hz)	50-60
Max Product power (kW)	7,33

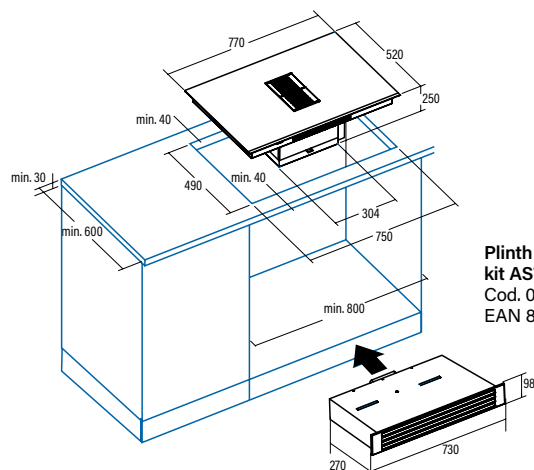

Plinth recirculating kit AS750
Cod. 02800939
EAN 8422248080330