



AS 600

Cod. **08000406** EAN **8422248198554**



- **Touch Control Panel** with timer and cleaning filters indicator
- 6 extraction levels, 5 + 1 **TURBO**
- Extraction power (according to UNE/EN 61591): **531m³/h** - 246m³/h
- **Sound power (Reg.(EU) n°65/2014): 45dB(A)**, maximum: 64dB(A)
- **BRUSHLESS** motor. Ultra silent. Maximum energy consumption **135W**
- Airflow speed: 10 m/s
- Easy-to-install system
- Dishwasher-washable filters
- Max. Pressure: 357 Pa - **TURBO** Pressure: 365 Pa
- 150 mm outlet diameter
- **Energy Class: A+**

4 cooking areas:

Front Right: 1 area **with Booster function** of 215mm x 190mm of 1.6 kW (max. 1.85kW)

Rear Right: 1 area **with Booster function** of 215mm x 190mm of 2.1 kW (max. 3kW)

Front Left: 1 area **with Booster function** of 215mm x 190mm of 1.6 kW (max. 1.85kW)

Rear Left: 1 area **with Booster function** of 215mm x 190mm of 2.1 kW (max. 3kW)

2 modular double areas measuring 215mm x 380mm of 3.7kW

- **Touch Control** with acoustic warning
- 9 adjustable power levels + **Booster**
- **Timer** function for each area
- **Countdown** alarm
- **Automatic** pan detection
- **Safety** lock
- **Residual** heat indicator
- **Automatic** safety switch-off
- **Frontal** bevel
- **59 cm** wide
- **Total power (induction + extraction) 7.53kW**

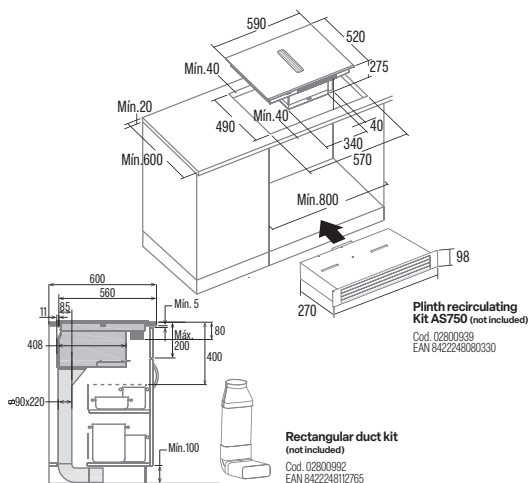

Code	08000406
EAN	8422248198554
Model	AS 600
Type	Surface
Product fiche according to directives EU65/2014 - EN61591, EN60704-2-13, EN50564	
AEC (Annual Energy consumption) (kWh/annum)	29
EEL class (Energy Efficiency Class)	A+
FDE (Fluid Dynamic Efficiency)	32
FDE class (Fluid Dynamic Efficiency Class)	A
LE (Lighting Efficiency) (lux/W)	-
LE class (Lighting Efficiency Class)	-
GFE (Grease Filtering Efficiency)	45,8
GFE Class (Grease Filtering Efficiency class)	F
Air flow at minimum speed (m³/h)	246,4
Air flow at maximum speed (m³/h)	446,3
Air flow at intensive speed (TURBO) (m³/h)	531,5
Sound Power Level at minimum speed (dB)	45
Sound Power Level at maximum speed (dB)	64
Sound Power Level at intensive speed (TURBO) (dB)	67
Po (Power Consumption in off mode) (W)	0,4
Ps (Power Consumption in standby) (W)	-
Integration directive EU 66/2014	
f (Time Increase Factor)	1
EEL (Energy Efficiency Index)	49,2
QBEP (Flow Rate at Best Efficiency Point) (m³/h)	264,2
PBEP (Static Pressure Difference at Best Efficiency Point) (Pa)	294
WBEP (Electric Power Input at Best Efficiency Point) (W)	79,4
WL (Nominal Power Consumption of Lighting system) (W)	0
EMIDDLE (Average Illumination of Lighting system on Cooking surface) (lux)	0
External Dimensions	
Width (mm)	590
Depth (mm)	520
Total max height(mm)	275
Total min height(mm)	-
Outlet Diameter (mm)	150
Characteristics	
Motor	BLDC
Extraction Levels	5+1
Motor Maximum Power Consumption	135
Maximum Pressure	-
Intensive Speed (TURBO) Pressure	-
Control Type	TC
Automatic shut-down timer	√
Electronic Filter Saturation Indicator	√
Filter Type	Metallic
Anti-grease Filter Number	2
Inner Shield	√
Lighting	
Light Type	-
Adjustable Intensity Lighting	-
Nº of Lamps	-
Installation	
Minimum height distance to a electric worktop hob (mm)	-
Minimum height distance to a gas worktop hob (mm)	-
Installation with Outlet tube to the exterior / Recirculating	BOTH
Easy Installation System	√
Electric Connection	
Total Rush Power (W)	7335
Rated Voltage (V)	220-240
Network Frequency (Hz)	50-60
Electrical Insulation Class	CLASE I
Plug	-
Accessories	
Upper Decorative tube Extension	-
White Decorative Tube	-
Black Decorative Tube	-
Island Tube Enhancer	-
Check Valve	-
MAX PRO Metal Filter	-
Metal Filter	02800935*
DUAL Filter (metal + active charcoal)	02800937
Active Charcoal Filter	02800939
Noiseless Flexible Duct	02893002